



# Delta

## PRODUCT CARD

### SHOWROOM

—

Parchment House  
13 Northburgh Street  
London EC1V 0JP

### CONTACT

—

info@workstories.com  
+44 (0)20 3735 5224  
workstories.com







# Delta

Designed by **M.A.D**

Our Delta collection has a striking triangular base that recalls the Greek letter Delta.



Available as poseur table, café table and high stool.



# Finishes

- Table top** – 9x standard MFC finishes. Bespoke finishes also available (incl. Forbo, Fenix, Veneer or Solid wood)
- Seat** – Natural ash, Black ash or Forbo with solid ply core
- Upholstery** – Any fabric of your choice
- Frame** – Black

# Materials

- Seat** – Upholstered moulded plywood shell, veneer
- Frame** – Powder-coated tubular steel



# Dimensions

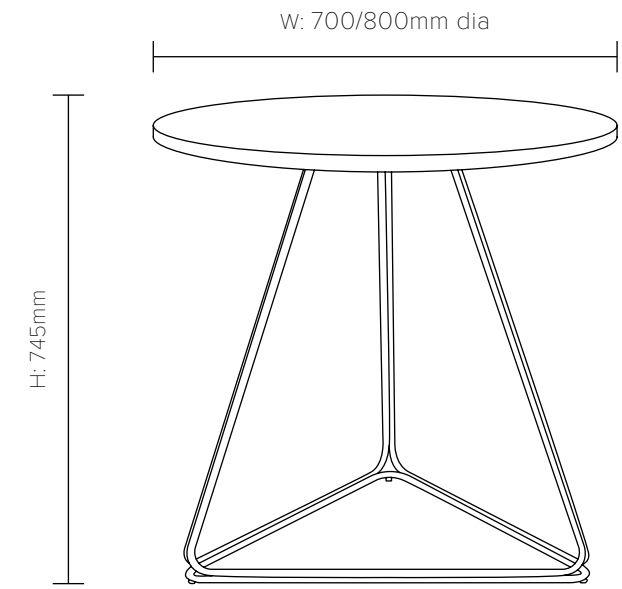

Café table

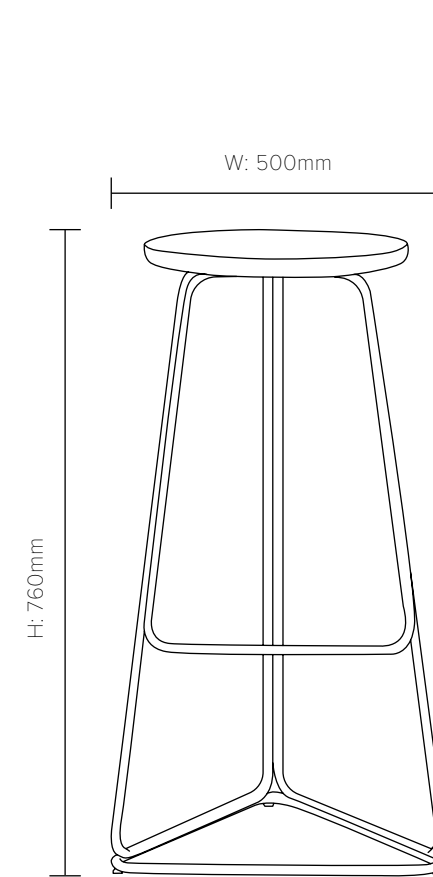

High stool



Poseur table

## Poseur table

Circular: 700/800/900mm dia  
 Square: 700x700/800x800mm  
 H: 1050mm

## Café table

Circular: 700/800mm dia  
 Square: 700x700/800x800mm  
 H: 745mm

## High stool

Base W: 500mm  
 Seat dia: 320mm  
 Seat (H): 760mm

Certificates

The Delta collection meets or exceeds ANSI/ BIFMA 5.5. Materials meet or exceed ANSI/ BIFMA M7.1 VOC emissions standards for office furniture.

General Care

CLEANING & CARE

– The furniture should be regularly cleaned with a soft, dry cloth in the direction of the wood grain. If required, a damp, soft cloth may be used. Do not use abrasive, ammonia, bleach, spirit or oil-based cleaners, including D10 sanitiser. Periodically check and tighten hardware as necessary. Any lost bumpers or feet should be replaced as soon as possible to avoid damage to the furniture or the floor surface.

UPHOLSTERY

– Upholstered furniture gets dusty and this can dull the colours and reduce the life of fabrics. Lightly vacuum or brush regularly but never use a stiff brush as this could damage the fibres. If you spill something on the upholstery, wipe excess liquid up immediately with a clean absorbent cloth. Then follow the fabric manufacturers cleaning instructions.

POWDER COATED METAL PARTS

– Clean with lukewarm soapy water and rinse off with clean water. Wipe the entire surface with a clean, dry cloth.

TOPS: MFC LAMINATE

– All MFC products can easily be cleaned with a damp cloth and a mild soap, or detergent if necessary, and buffed dry with a clean cloth. Never use abrasive powders or scouring pads to clean stubborn marks. In extreme circumstances, a mild alcohol product can be used, however this must be followed by a damp cloth soaked in water, ensuring no alcohol residue is present afterwards.

SAFETY WARNINGS

– Furniture can be dangerous if improperly assembled or installed. Assembly should be completed by a qualified person following the provided assembly instructions.

Do not stand on furniture, as it could cause a fall. With assistance of another person, always lift, do not drag large or heavy furniture into position.

Warranty

Workstories Ltd offers a 5-year warranty on our M.A.D range.

This applies only if products have been used within and by standard office conditions. Wear and tear must be expected from normal use and are not covered by the warranty.

Environmental Practices

Workstories is dedicated to being environmentally conscious. We strive to ensure the continued availability of natural resources for current and future generations, and as part of our mission, we recognise the responsibility to protect human health and the environment, and to continually improve our operations.

To carry out this commitment, it is our policy to ensure all our factories:

Meet or exceed the requirements of all environmental laws and regulations applicable to our operations.

Limit our impact on the environment to the extent practicable and work to reduce recognised environmental risks to our employees and the communities in which we operate by employing safe technologies and operating procedures.

Continually assess our environmental programs and monitor our environmental performance.

Have operating policies and programs in place to implement our Environmental Quality Policy.



Last updated: 13/07/2023

*workstories...*

[workstories.com](https://workstories.com)