



Sling

PRODUCT CARD

SHOWROOM

—
Parchment House
13 Northburgh Street
London EC1V 0JP

CONTACT

—
info@workstories.com
+44 (0)20 3735 5224
workstories.com





Sling

Designed by **M.A.D**

Our best-selling collection, the Sling family ticks all the boxes: modern, comfortable and functional. It is highly popular due to the flexibility of its bespoke British upholstery and a style that fits a multitude of purposes and environments.

The collection features a rear leg which follows the angle of the back, becoming both a structural support and design feature at the same time.



A collection with side chair, lounge chair and bar stool.

Side chair:
MAD/G42U/BLK/UPH

Lounge chair:
MAD/G42L/BLK/UPH

Bar stool:
MAD/G42B/BLK/UPH

Finishes

Upholstery – Any fabric of your choice
Base – Black

Materials

Seat – Upholstered moulded plywood shell
Base – Powder-coated tubular steel



Dimensions

Stool

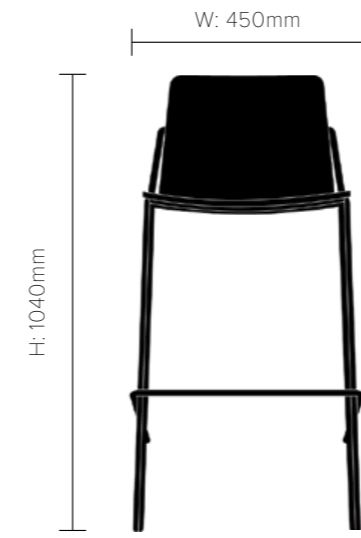

Side

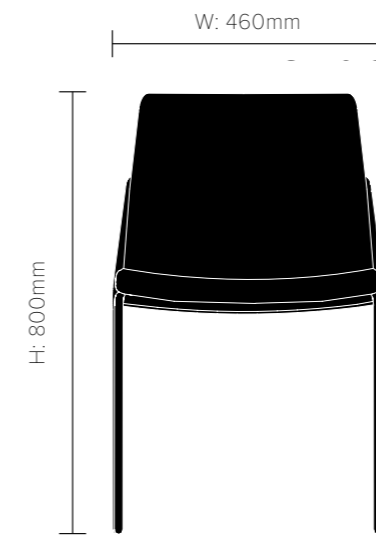

Lounge

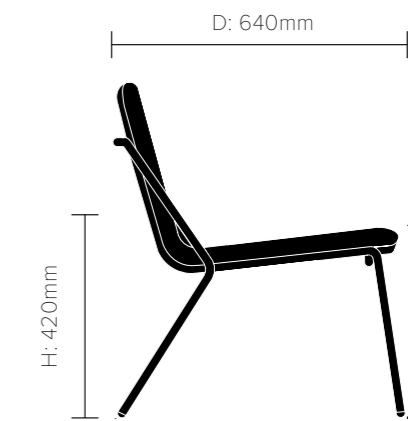
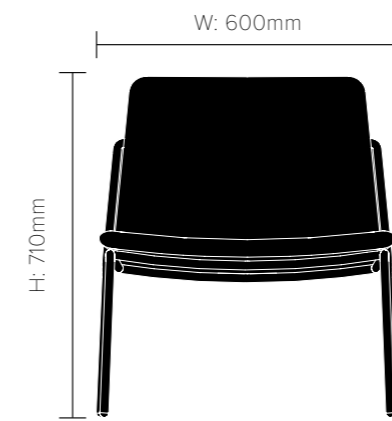

Stool

W: 450mm
D: 510mm
H: 1040mm
Seat (H): 750mm

Side

W: 460mm
D: 520mm
H: 800mm
Seat (H): 500mm

Lounge

W: 600mm
D: 640mm
H: 710mm
Seat (H): 420mm

Fabric bands

	BAND 1	BAND 2	BAND 3	BAND 4	BAND 5	BAND 6	BAND 7	BAND 8
AGUA		Buro	Tones					
BUTE					Alchemy		Storr	
					Melrose		Tiree	
					Mercury			
CAMIRA	Citadel	Advantage	Halycon: Aspen Blossom Cedar	24/7 Flax	Armadillo	Corrosion		
	Era	Aspect		Aquarius	Craggan Flax	Synergy Quilt: Channel Chevron Hourglass		
	Gravity	Main Line Flax		Blazer	Yoredale			
	Phoenix	Main Line Plus	High Tech	Silk				
	Rivet	Manhattan	Oceanic	Track				
		Patina	Synergy					
		Urban Plus	Sumi					
		Vita Vinyl						
		X2						
	Xtreme							
Quest								
CHIEFTAIN		Just Colour Vinyl	Lionella					
GABRIEL		Noma	Step	Crisp	Breeze Fusion		Comfort plus	
			Step Melange					
KVADRAT				Canvas	Divina 3	Divina MD	Coda	Razzle Dazzle
				Clara 2	Divina Melange 3		Sunniva	
					Field		Twill Weave	
					Fiord			
					Flyod			
					Hallingal			
					Remix			
					ReWool			
					Steelcut			
					Steelcut Trio			
				Tonica 2				
PANAZ		Cadet Vinyl		Aston				
ROMO				Laser FR	Leaf II / Leaf Recycled			
				Sahara FR	Smooth FR			
				Geneva FR	Tone			
SAHCO						Cuba		
SPECTRUM			Spectrum Vinyl					
SVENSSON				Easy	Accessoire			
				Harper	Be On			
				Semi	Heritage			
				Tone	Moss			
				Urban	Rami			
					Revolt			
				Vy				

	BAND 1	BAND 2	BAND 3	BAND 4	BAND 5	BAND 6	BAND 7	BAND 8
VESCOM				Furka Plus		Ponza		
ULTRA LEATHER					UL Original			
					UL Brisa			
YARN COLLECTIVE							Ismay Boucle	
YARWOOD		Dollaro Faux Leather						

This list is for guidance only and not exhaustive.
If the fabric you are after is not above, please send your enquiry to the Sales team.



Certificates

The Sling collection is ANSI/BIFMA X5.1 certified. Materials meet or exceed ANSI/BIFMA M7.1 VOC emissions standards for office furniture.

Workstories guarantees limited carbon footprint for our products. Workstories is a full member of FIRA, and holds ISO9001 and ISO14001 certifications.



General Care

CLEANING & CARE

The furniture should be regularly cleaned with a soft, dry cloth in the direction of the wood grain. If required, a damp, soft cloth may be used. Do not use abrasive, ammonia, bleach, spirit or oil-based cleaners, including D10 sanitiser. Periodically check and tighten hardware as necessary. Any lost bumpers or feet should be replaced as soon as possible to avoid damage to the furniture or the floor surface.

UPHOLSTERY

Upholstered furniture gets dusty and this can dull the colours and reduce the life of fabrics. Lightly vacuum or brush regularly but never use a stiff brush as this could damage the fibres. If you spill something on the upholstery, wipe excess liquid up immediately with a clean absorbent cloth. Then follow the fabric manufacturers cleaning instructions.

POWDER COATED METAL PARTS

Clean with lukewarm soapy water and rinse off with clean water. Wipe the entire surface with a clean, dry cloth.

SAFETY WARNINGS

Furniture can be dangerous if improperly assembled or installed. Assembly should be completed by a qualified person following the provided assembly instructions.

Do not tilt, or lean back on the chair legs, as this could result in a fall. Do not stand on furniture, as it could cause a fall. With assistance of another person, always lift, do not drag large or heavy furniture into position.

Warranty

Workstories Ltd offers a 5-year warranty on our M.A.D range.

This applies only if products have been used within and by standard office conditions. Wear and tear must be expected from normal use and are not covered by the warranty.

Environmental Practices

Workstories is dedicated to being environmentally conscious. We strive to ensure the continued availability of natural resources for current and future generations, and as part of our mission, we recognise the responsibility to protect human health, the environment, and natural resources, and to continually strive to improve the environmental quality of our operations.

To carry out this commitment, it is our policy to ensure all our factories:

Meet or exceed the requirements of all environmental laws and regulations applicable to our operations.

Limit our impact on the environment to the extent practicable and work to reduce recognised environmental risks to our employees and the communities in which we operate by employing safe technologies and operating procedures.

Continually assess our environmental programs and monitor our environmental performance.

Have operating policies and programs in place to implement our Environmental Quality Policy.



Last updated: 08/04/2022

workstories...

workstories.com