



*workstories..*

# ASSEMBLY GUIDE



ALBION

**Breakout**

Pedestal Tables - Coffee / Meeting / Poseur

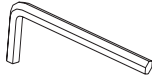

Info@workstories.com  
020 3735 5224  
workstories.com

*standard*

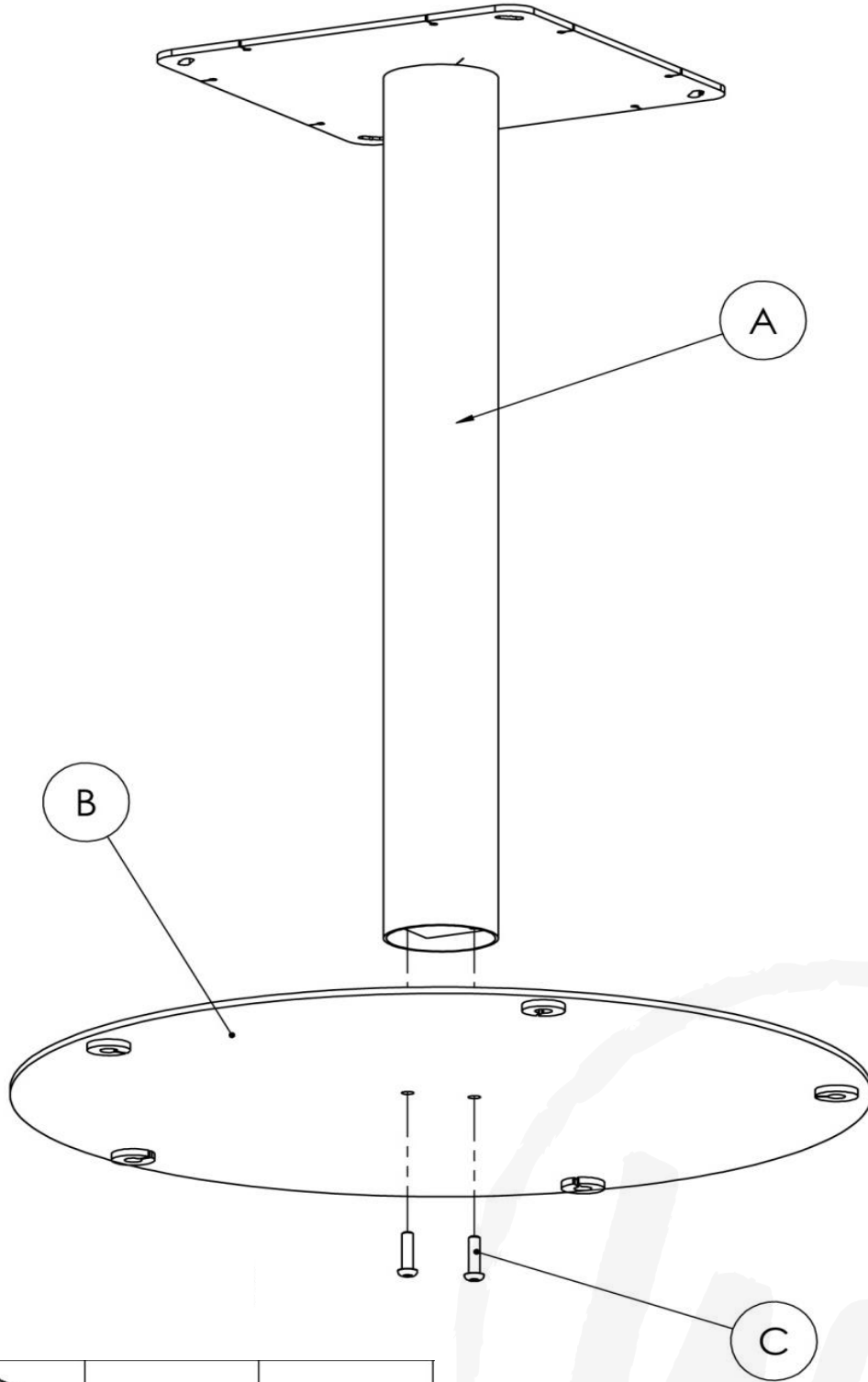

hardware	tool required	
2x M8x30 hex head 4x M6x15mm bolts for top fixing		
	5mm allen key	Pozi screw driver

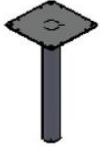
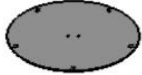
Assemble upside down







			
	PILLAR BASE UPRIGHT	ROUND BASE	M8 X 30 HEX HEAD
Pcs	A	B	C
Qty	1	1	2

*standard / with weight*

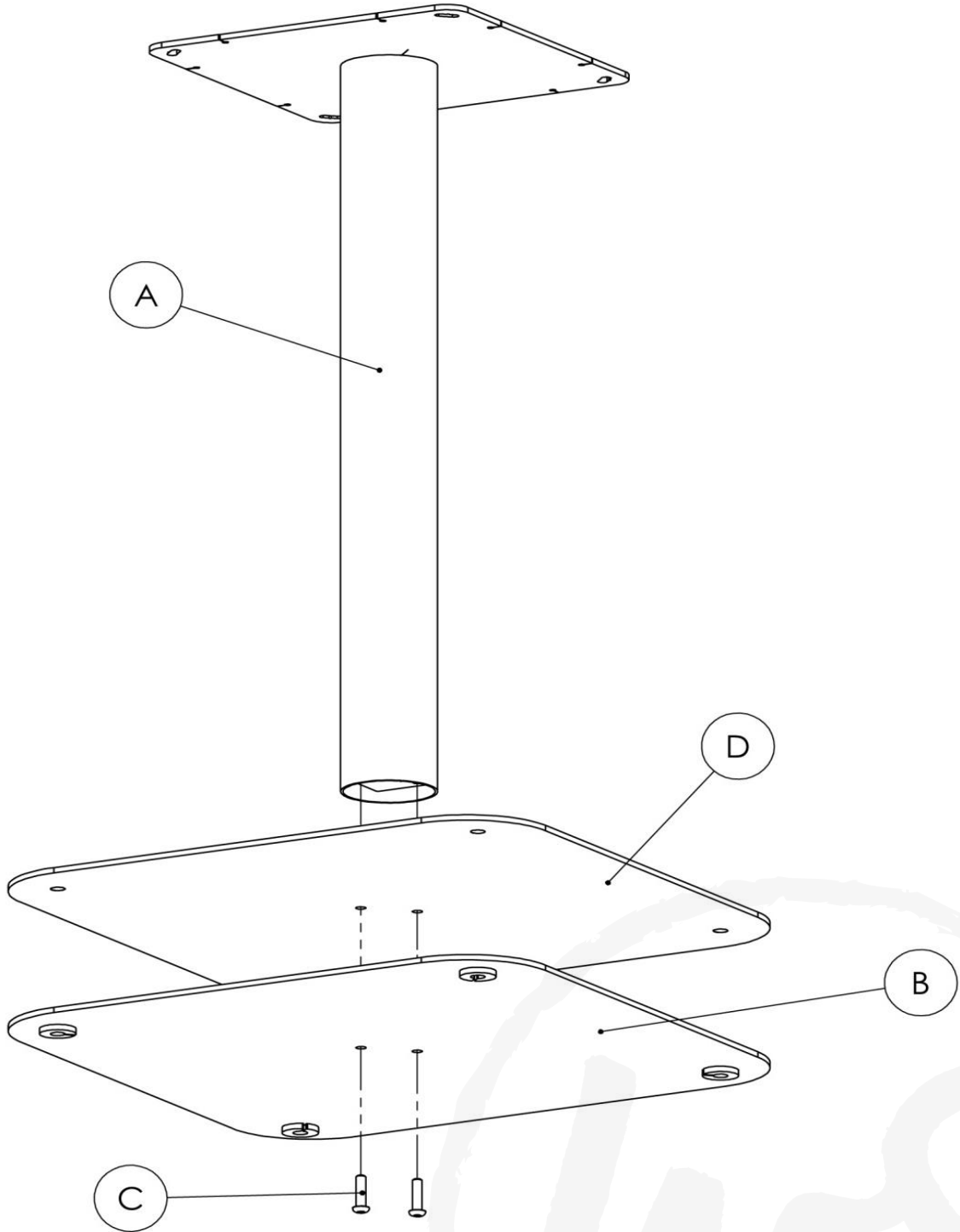

hardware	tool required	
2x M8x30 hex head 4x M6x15mm bolts for top fixing		
	5mm allen key	Pozi screw driver

Assemble upside down

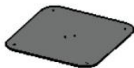



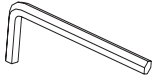

				
	PILLAR BASE UPRIGHT	SQUARE BASE PLATE	M8 X 30 HEX HEAD	WEIGHT PLATE
Pcs	A	B	C	D
Qty	1	1	2	1

*power managed*

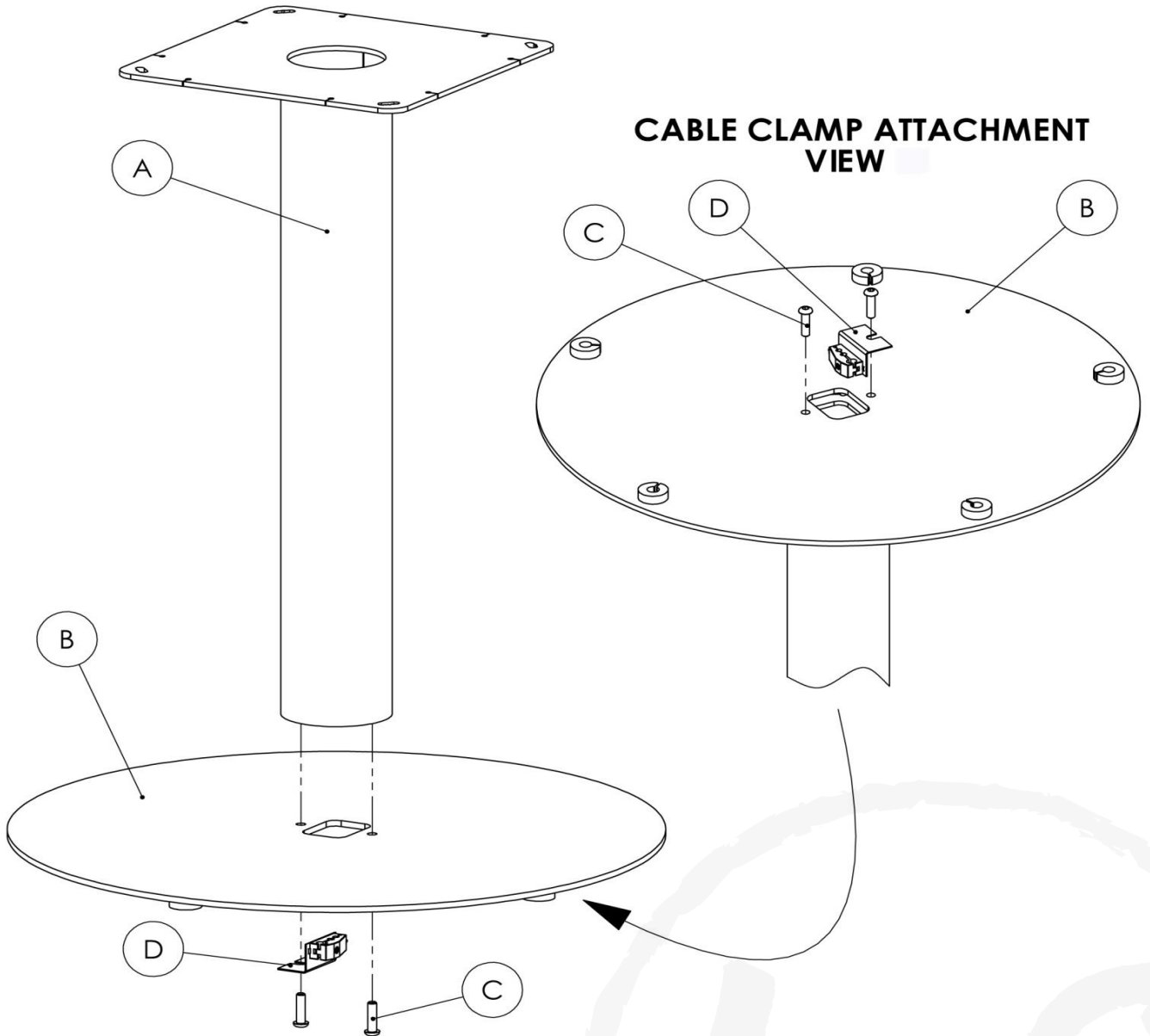
hardware	tool required	
2x M8x30 hex head 4x M6x15mm bolts for top fixing		
	5mm allen key	Pozi screw driver

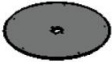

Assemble upside down



				
	PILLAR BASE UPRIGHT	ROUND BASE PLATE	M8 X 30 HEX HEAD	CABLE CLAMP ASSY
Pcs	A	B	C	D
Qty	1	1	2	1





*power managed*  
*/ with weight*

hardware	tool required	
2x M8x30 hex head		
4x M6x15mm bolts for top fixing	5mm allen key	Pozi screw driver

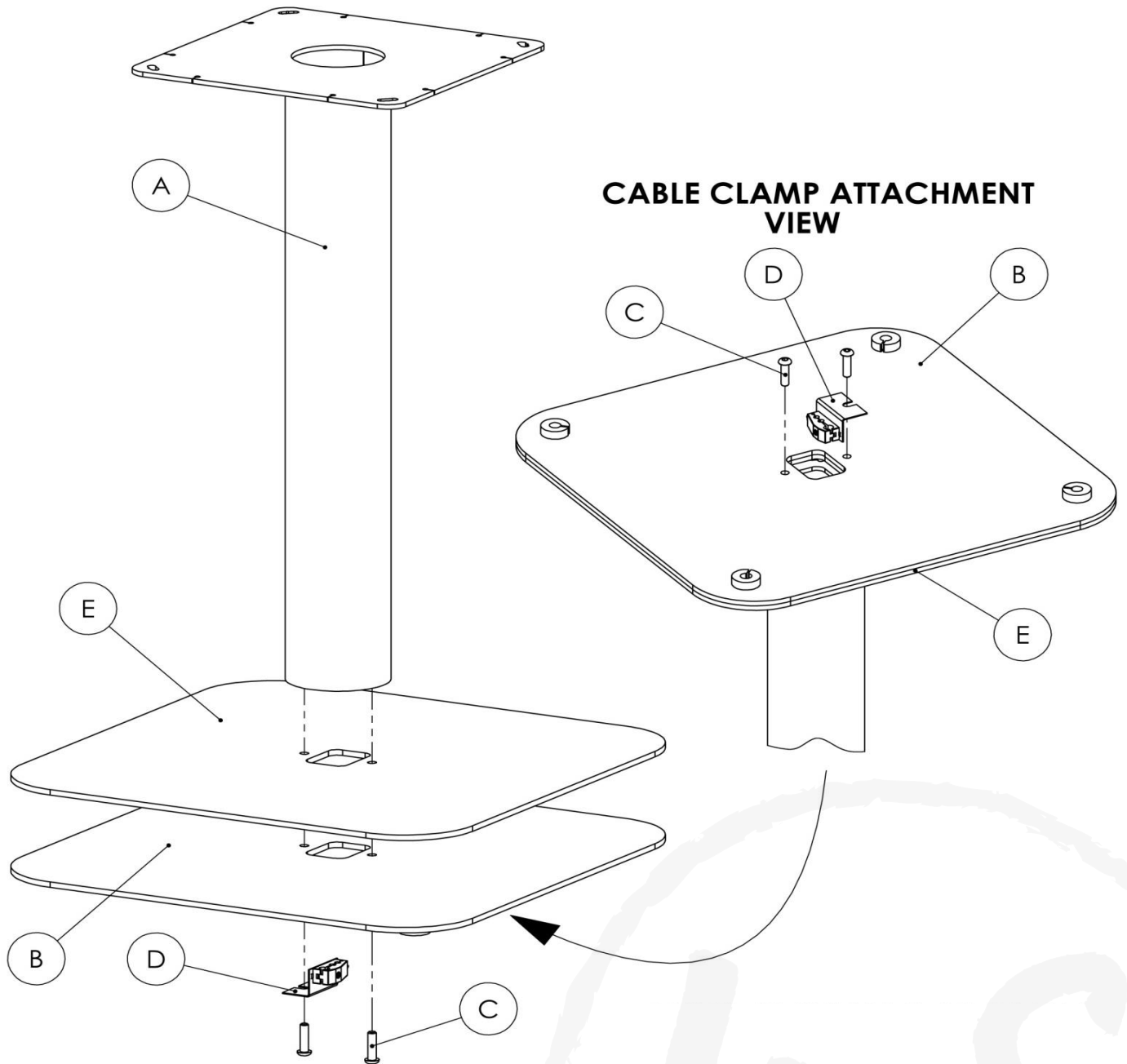
Assemble upside down

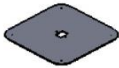

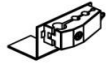
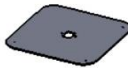
				
PILLAR BASE UPRIGHT	SQUARE BASE PLATE	M8 X 30 HEX HEAD	CABLE CLAMP ASSY	WEIGHT PLATE
A	B	C	D	E
1	1	2	1	1



**SHOWROOM**

13 Northburgh Street,  
London EC1V 0JP

**CONTACT**

Info@workstories.com  
+44 (0)20 3735 5224

**workstories.com**