



Contour Lounge

PRODUCT CARD

SHOWROOM

—
Parchment House
13 Northburgh Street
London EC1V 0JP

CONTACT

—
info@workstories.com
+44 (0)20 3735 5224
workstories.com



atelier

Contour Lounge

Designed by **ATELIER**

Contour is designed to reflect and transcend the modern workplace with its soft, flowing lines and elegant proportions. A timeless aesthetic coupled with enduring comfort; Contour elevates all environments in which it sits.



The Contour lounge can be beautifully accompanied by the Contour lounge stool, allowing for versatility in break out spaces.

Finishes

Upholstery – Any fabric of your choice
Base – Black

Materials

Seat – Upholstered polyurethane foam with an internal steel armature
Base – Aluminium



Dimensions

Contour lounge

H: 930mm
W: 795mm
D: 771mm

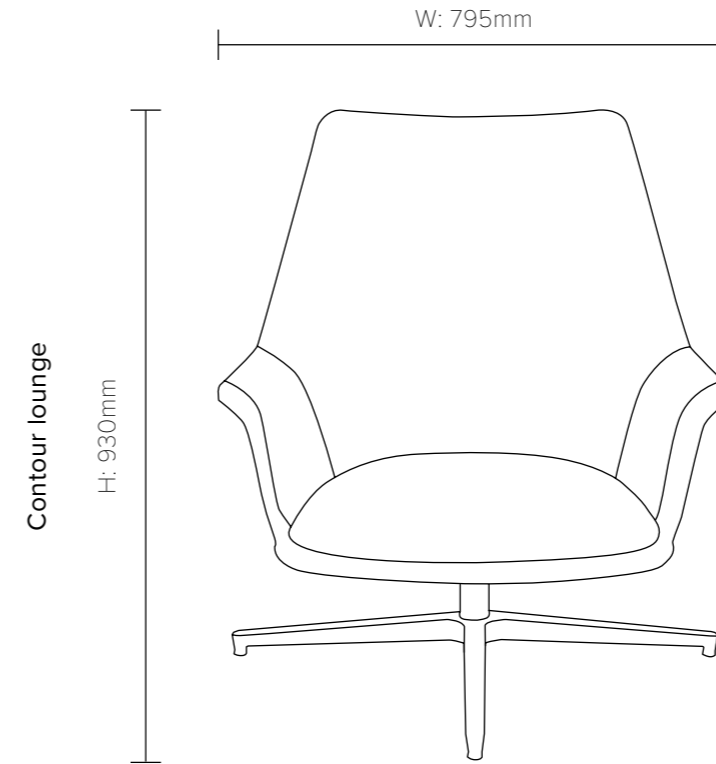

Contour stool

H: 385mm
W: 600mm
D: 487mm

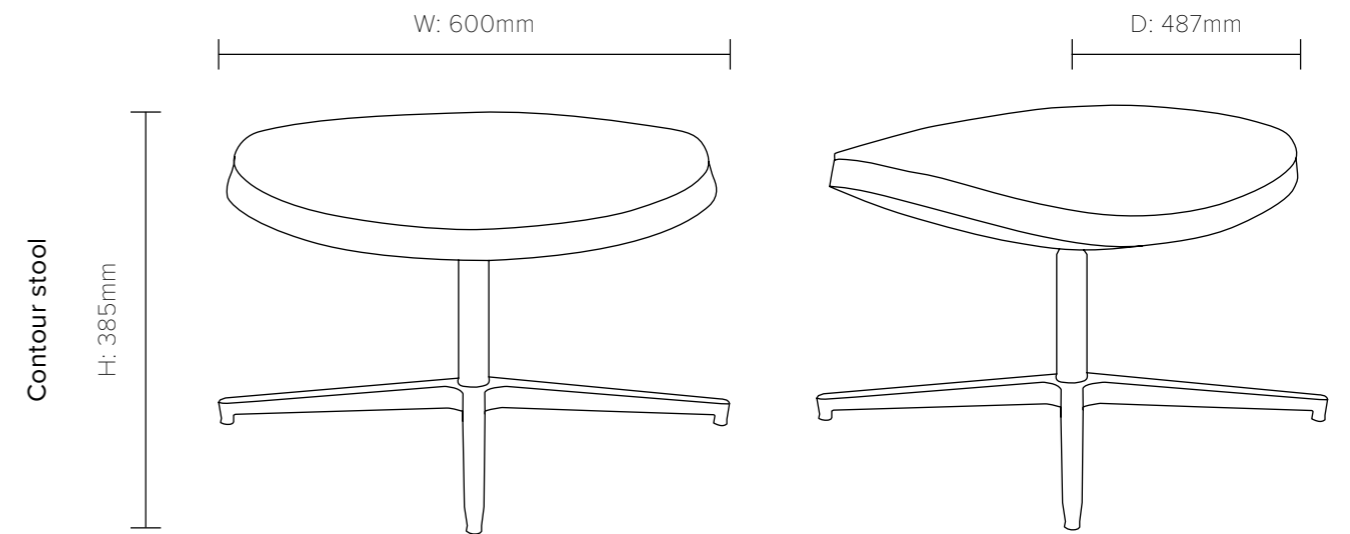



Warranty Certificates

The Contour chair passed the BS EN 16139: 2013 Test Level 1 General contract use.

The Contour chair is registered with ACID (Anti Copying In Design).

Workstories Ltd offers a 5-year warranty on our Atelier range.

This applies only if products have been used within and by standard office conditions. Wear and tear must be expected from normal use and are not covered by the warranty. Manufacturer's warranty applies to all fabrics.

General Care

CLEANING & CARE

– The furniture should be regularly cleaned with a soft, dry cloth. If required, a damp, soft cloth may be used. Do not use abrasive, ammonia, bleach, spirit or oil-based cleaners, including D10 sanitiser. Periodically check and tighten hardware as necessary.

UPHOLSTERY

– Upholstered furniture gets dusty and this can dull the colours and reduce the life of fabrics. Lightly vacuum or brush regularly but never use a stiff brush as this could damage the fibres. If you spill something on the upholstery, wipe excess liquid up immediately with a clean absorbent cloth. Then follow the fabric manufacturers cleaning instructions.

Environmental Practices

During the design process we ensured that any aspects of the design which could be produced using recyclable or recycled materials, was done so. Using die-cast aluminium for the 4-star, 4-star with castors, 5 star with castors and 4 star lounge base, aluminium is infinitely and widely recyclable. Mild steel forms the sled and 4 leg base, steel as an average contains 25% previously recycled steel and is recyclable at the end of its life.

Where plastic components were required for use (such as foot glides), we liaised directly with the supply chain to ensure that the plastic components were easy to disassemble and could be recycled by the end user. Ensuring that Contour is modular is another key to its sustainable credentials, bases can be interchanged at any time and are not moulded into the chair.

The upholstery was also designed to be easy to remove and re-upholster, achieved using a zipped jacket, whilst a removable seatpad and headrest ensure these high-wear areas can be re-upholstered individually without the requirement to disassemble and re-upholster the whole chair. This consideration for the upholstery cover will allow the internal frame and foam of the chair to be continuously used and recovered throughout the product lifespan. Where we have not been able to use recycled or recyclable materials, we have ensured that the specification of the material used is hardwearing and built to last.

Workstories is dedicated to being environmentally conscious. We strive to ensure the continued availability of natural resources for current and future generations, and as part of our mission, we recognise the responsibility to protect human health, the environment, and natural resources, and to continually strive to improve the environmental quality of our operations.

To carry out this commitment, it is our policy to ensure all our factories:

Meet or exceed the requirements of all environmental laws and regulations applicable to our operations.

Limit our impact on the environment to the extent practicable and work to reduce recognised environmental risks to our employees and the communities in which we operate by employing safe technologies and operating procedures.

Continually assess our environmental programs and monitor our environmental performance.

Have operating policies and programs in place to implement our Environmental Quality Policy.



Last updated: 09/08/2023

workstories...

workstories.com